

AST-IRT Refrigerant Transmitters

**Analog transmitters
with infrared sensors
for accurate, specific
refrigerant leak
detection**

OPERATION MANUAL



The AST-IRT NON-DISPERSIVE IR REFRIGERANT GAS SENSOR was designed to detect for the presence of specific refrigerant gases within an enclosed space. The sensor is mounted within the space to be monitored and connected by cable to a monitoring device. Each sensor is calibrated to monitor for a specific refrigerant gas. There are two models of IR sensor for each gas depending upon the monitoring environments: Machine room, for most applications above freezing and Cold Room for low temperature refrigerated room applications. There are three housing options: NEMA 3R Aluminum (Pictured), water-tight ABS fiberglass housing for Wash down protection NEMA 3R, and Stainless Steel NEMA 3R enclosure also available for special applications. The IR Sensor is a reliable method of monitoring for refrigerant gas leaks in environments that have air quality problems. The IR sensor will eliminate many false alarms in environments that contain gasoline, diesel, and propane exhaust and fumes from solvents, paints, cleansers, and others.

APPLICATIONS

Typical applications include:

- HVAC Chiller Equipment Rooms
- Wineries
- Refrigeration Mechanical Rooms
- Bakeries
- Food Processing Plants
- Refrigerated Rooms

Critical Environment Technologies

145 - 7391 Vantage Way
Delta, BC V4G 1M3

Toll free: 877-940-8741
Phone: 604-940-8741
Fax: 604-940-8745



AST-IRT Refrigerant Transmitters

SENSOR TYPE

Non-dispersive infrared sensor, calibrated to monitor for a specific refrigerant gas.

REFRIGERANT GAS TYPE

Ammonia R717 (NH3)

R11

R12

R22

R114

R123

R134A

R401A (MP89)

R401B (MP66)

R402A (HP80)

R404A (HP62)

R407C (9000)

R408A (FX10)

R409A (FX56)

R500

R502

R507A (AZ50)

OPTIONS

Watertight ABS Fiberglass Housing

Stainless Steel Housing

INSTALLATION

Mount securely on a wall with little or no vibration.

Install in vertical position only.

For refrigerants mount 18" to 24" from the floor

For Ammonia mount on or near the ceiling

CALIBRATION

Zero adjustment recommended at six month intervals

SPECIFICATIONS

ENCLOSURE

Standard Painted Aluminum

Size 12.9" x 4.8" x 2.5"

327 mm x 122 mm x 62 mm

Weight 2 pounds 900 grams

RANGE

0 - 1032 ppm

SENSITIVITY

+/- 1 ppm at 25 degrees C, 45% RH

RESOLUTION

1 ppm

ACCURACY

+/- 5 ppm plus 2% over full scale

RESPONSE TIME

Under 60 seconds

OPERATING TEMPERATURE

Standard model

0 to 43 degrees C 32 to 110 degrees F

Freezer Room model

-40 to 43 degrees C -40 to 110 degrees F

HUMIDITY

0 to 90% RH non condensing

CERTIFICATION

ETL

OUTPUT

Linear 4 to 20 mA signal

POWER & WIRING

10 to 36 Volts DC

Three conductor, 18 gauge shielded

AST-IRT Refrigerant Transmitters

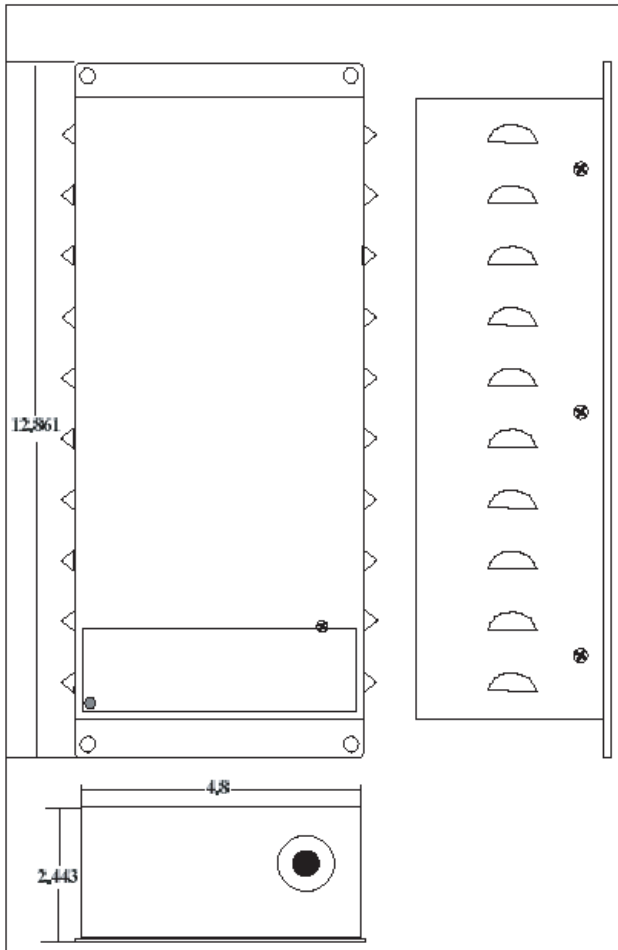

Fig. 4 Nema 3R Aluminum Enclosure Dimensions

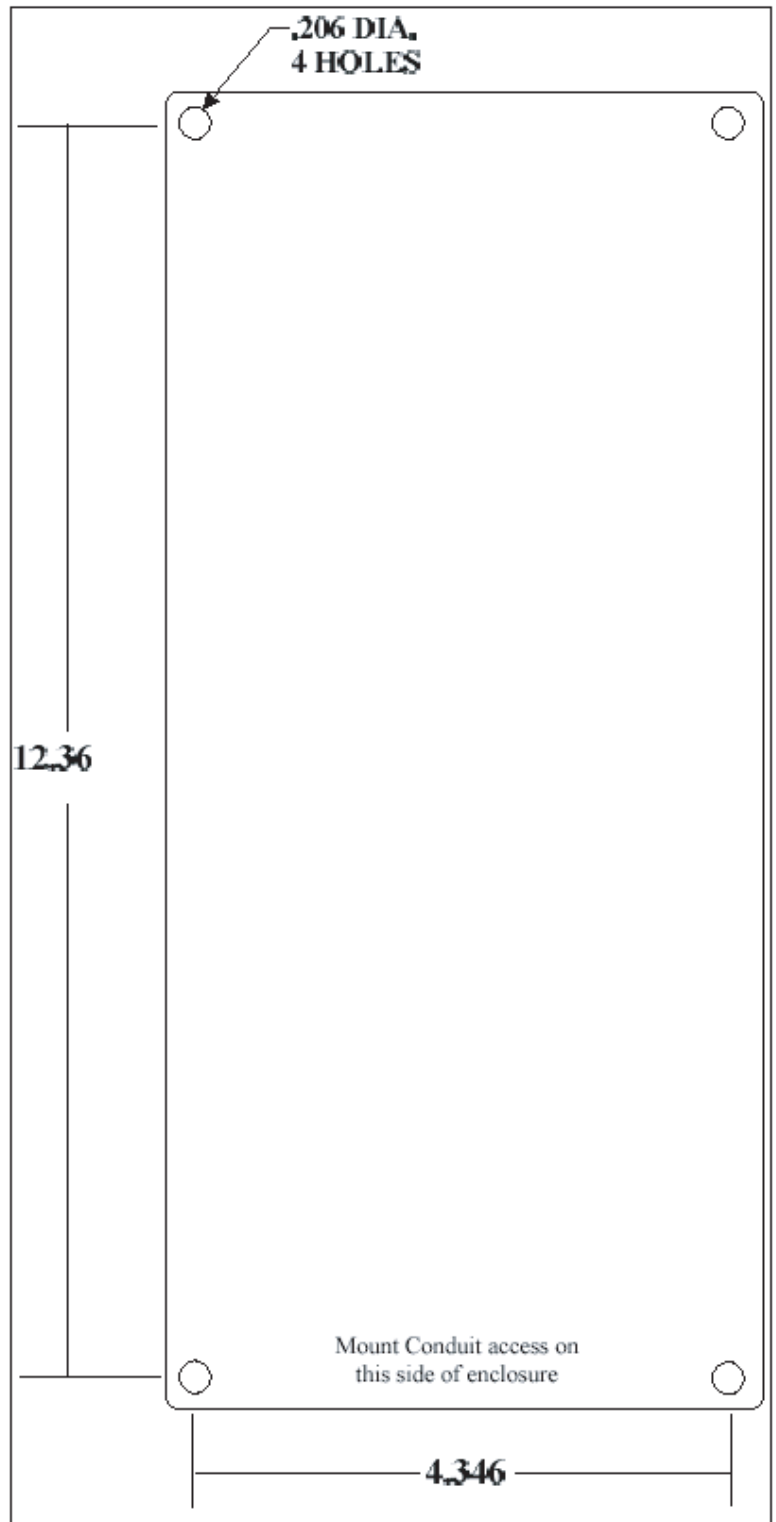

Fig. 5 Mounting Diagram, Nema 3R Encl.

AST-IRT Refrigerant Transmitters

MOUNTING INSTRUCTIONS

Sensor Placement.

The AST-IRT Refrigerant Gas Sensor must be placed in locations that a refrigerant gas leak is likely to occur and where leaked refrigerant gas is likely to concentrate so as to provide warning of a potentially hazardous condition. Mounting locations are dependent upon the application and the refrigerant gas to be monitored. The housing has a 3/4" conduit knockout hole in the bottom so the sensor must be mounted vertically.

All mounting locations must be a fixed, well supported wall, pole or frame with little or no vibration. Sensors must be placed in locations that will prevent damage from fork trucks, carts, and other moveable devices.

For Halocarbon refrigerants, place the sensor 18 to 24 inches off the floor.

For Ammonia (R717), place the sensor 18 to 24 inches from the ceiling.

Use only watertight fittings, either conduit fittings or cable retention fittings. Mount conduit on the bottom side of the housing to prevent moisture from dripping on the control board.

HVAC/Refrigeration Machinery Room

Prior to placement of the IR Leak Sensors, the room air currents need to be determined. Air currents can be determined through the use of smoke candles or any other accepted field-expedient method. The air currents of every potential condition should be analyzed. The maximum air flow rate past the sensor should not exceed 3 feet per second. Air velocity past the sensor can be determined by lighting a match close to the sensor. If the match is blown out by the air current, mounting the sensor inside a pull box with the knockouts opened slightly or some other method of damping the air must be used.

Exhaust Fan On -- The air currents within the machinery room exhaust fan must be determined. Identify locations that are "downwind" of the potential leak source. Locate one sensor near the air intake duct of the exhaust fan, but not directly in the duct so the sensor is not subject to the full force of the duct air.

Exhaust Fan Off -- In applications where the machinery room exhaust fan can be shut off, identify air currents of the machine room with the fan off. Locate a position "downwind" of the potential leak source with the fan off. This location may be omitted if the exhaust fan is to be operated continuously.

Refrigerated Room

Determine the direction of the discharge air from the evaporator coil.

Halocarbon Refrigeration Systems -- Mount the sensor on a wall near the return air vents of the evaporator coil or within between ten to twenty feet of a doorway exiting the room to a space. Also 18 to 24 inches above the finished floor. Use of a "J" box or some other form of protection for the sensor may be necessary.

Ammonia Refrigeration Systems -- Mount the sensor on a wall in the downwind air path of the discharge air, at least 20 feet or more from the coil or on the wall on the opposite side of the room. 18 to 24 inches from the ceiling. Do not place the sensor closer than 10 feet from the coil or directly in the discharge air path to avoid temperature fluctuations due to defrost and violent air circulation.

AST-IRT Refrigerant Transmitters

Mounting

The sensor must be mounted with the wire terminal blocks oriented to the lower right and the sampling chamber in a vertical position. Failure to mount the sensor in this fashion may result in false or inaccurate readings and can allow moisture to enter the housing and destroy the sensor.

Wall Mount.

Use locally available wall mounting hardware, such as molly-bolts or toggle bolts, to firmly affix the sensor to the wall. The sensor should be mounted using the mounting feet mounted on the back of the housing. Ensure that all four sets of mounting feet are accessible. Hold down the mounting feet with the locally available wall mounting hardware.

Pole Mounting.

The sensor can be mounted to a support pole by utilizing Uni-Strut type C braces. Attach the C-braces to the back of the housing, perpendicular to the sensing chamber direction. Attach clamps to the C-brace and run stainless steel band straps around the pole and through the straps.

Cable Runs.

All cabling must avoid running parallel to high voltage (48 VDC or greater or any AC voltage wiring). Cable must be greater than 12 inches from high voltage wiring or conduit. Avoid running cable near all inductive loads, such as motors, fluorescent fixtures, transformers. Depending upon local codes, sensor cabling may be run loose or be placed into conduit used exclusively for low voltage control wiring.

Sensor cable shall have the minimum specifications:

- For cable runs of 0 to 1000 feet
- 18 AWG, Twisted Pair/Triad,
- Shielded, Stranded Wire.
- (Belden 8770 or equivalent)
- Stand Alone sensor applications
- of any length
- 18 AWG, 4 Wire, 2 Pair, Twisted,
- Shielded.
- (Belden 9552 or equivalent)

SENSOR WIRING

Wire sensors according to diagram

"R" - Red Wire = V+

"B" - Black Wire = Ground

"G" Green Wire = Signal or In

LEGEND

"R" RED = V+

"B" BLACK = GROUND

"G" GREEN = IN/SIGNAL

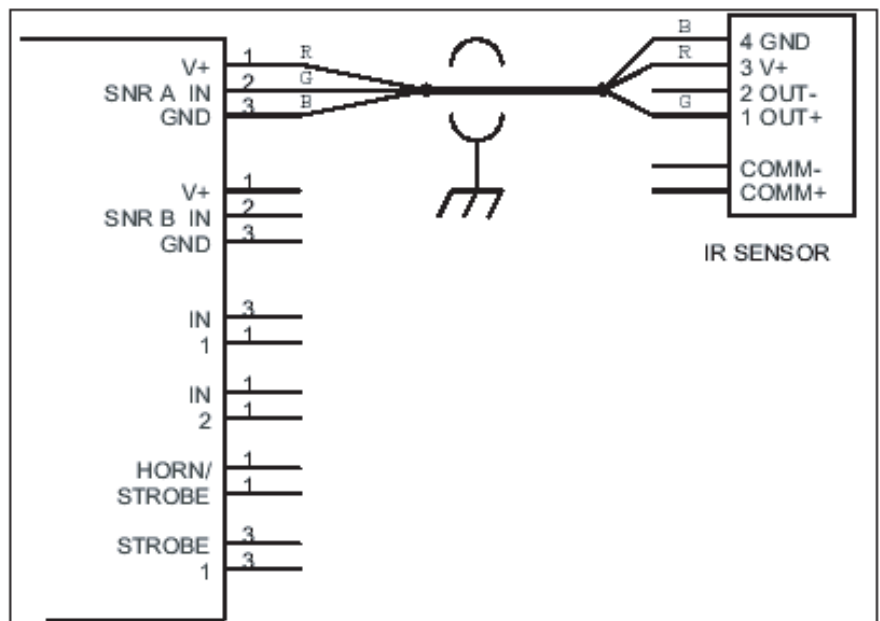

AST-IRT Refrigerant Transmitters

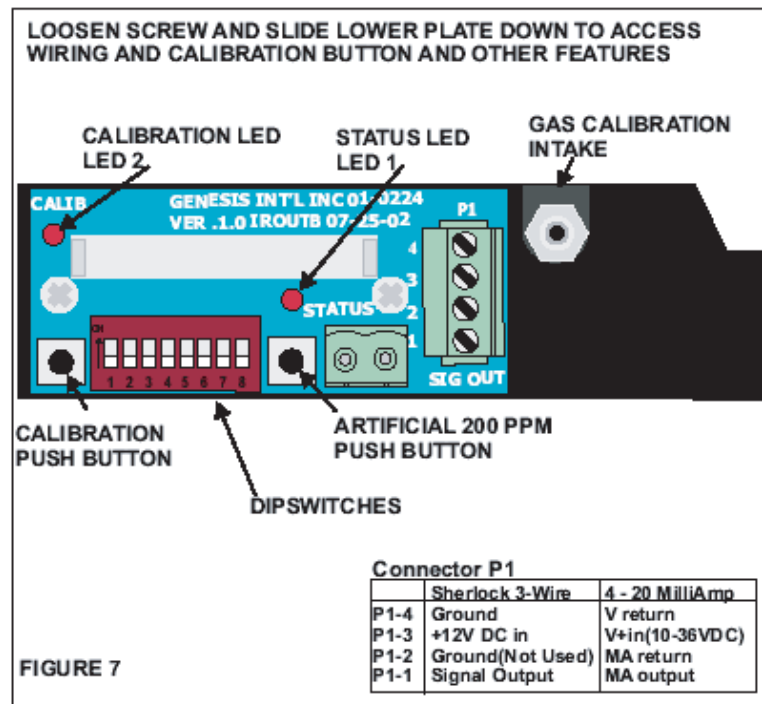

OPERATION

Components Description and Use.

Dip Switch -- Switches 1 to 8 are set to off at the factory. This is the standard dip switch setting for normal operation

Switches 1, 2, and 3 - Switches 1, 2, and 3 are for communications port addressing.

Switch 4 - Switch 4 is for auto long term zero compensation. It will recalibrate up to 10 ppm every 7 days. No more than 100 ppm between manual calibrations. Disable for low level detection.

On zero Compensation SW4 = OFF

Disabled SW4 = ON

Switch 5 - Switch 5 is for field testing at a set level.

Normal SW5 = OFF

Fixed 200 ppm output SW5 = ON

Switch 6 - Switch 6 is for factory calibration.

Normal SW6 = OFF

Default Factory setting SW6 = ON

Switch 7 - Switch 7 is used to tell the microprocessor on board whether the sensor will be utilized as a control system sensor or a stand-alone sensor.

Control SW7 = OFF

Standalone (4-20mA) SW7 = ON

Switch 8 - Switch 8 is not used

AST-IRT Refrigerant Transmitters

OPERATION continued

Push buttons - Located just on either side of the DIP Switch.

Push button 1 It is used for testing the sensor with a 200 ppm false signal. Dipswitch 5 can be used for the same function.

Push button 2 It is used for sensor calibration and is used in conjunction with LED 2

Light Emitting Diodes (LED)

LED L1 will indicate if the sensor microprocessor is operating and if the sensor is in test mode. When the microprocessor goes through start-up, it will turn on L1 and keep it on unless switch 5 is on or pushbutton 1 is depressed.

Status	Condition
Off	Sensor is not powered up. Microprocessor detects an error in the sensor hardware. Microprocessor Failure
ON Steady	Sensor is operating properly.
ON Flashing	Switch 5 is set to on or pushbutton 1 is depressed or microprocessor error.

LED L2 is used for zero calibration. When pushbutton 2 is pressed, LED 2 will light after 8 seconds and turn off once the button is released.

Status	Condition
Off	Normal operation
ON Steady	Factory Calibrated Setting. Turn switch 6 off
ON Flashing	Microprocessor error. Call factory.

Potentiometers. The AST-IRT contains several potentiometers used in factory testing and calibration. They are located inside the main part of the housing and there should be no need to open this part of the sensor to make any adjustments. It is not recommended to do so as this could void the warranty and cause permanent damage to the sensor.

The AST-IRT has an effective sensing range of 0 to 1032 ppm. Suggested wiring for the transmitter is on the next page.

4-20 MA Sensor/ Transmitter

0 - 3.95ma - Sensor Malfunction

4.0ma - 0 ppm

19.5ma - 1000 ppm

The performance equations is:

$MA\ reading = ppm * 0.01551 + 4.0$

Note: This mapping is for standalone 4-20 milliamp output only.

AST-IRT Refrigerant Transmitters

WIRING DIAGRAM

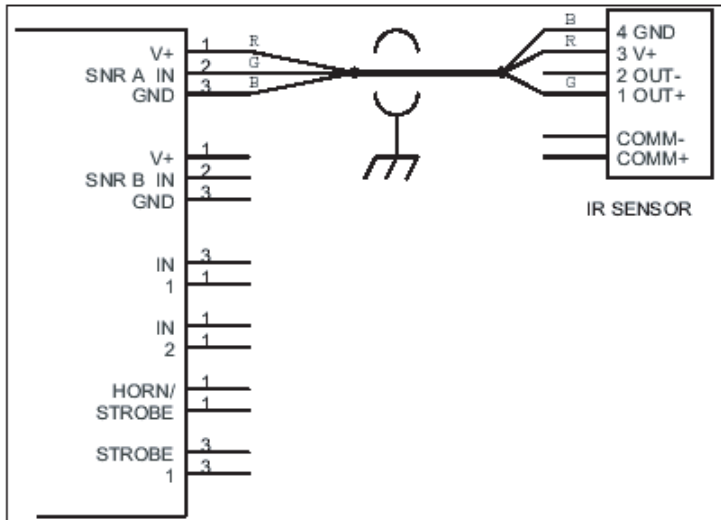

LEGEND

"R" RED = V+

"B" BLACK = GROUND

"G" GREEN = IN/SIGNAL

CALIBRATION

Prior to shipment, all sensors manufactured are factory calibrated. The calibration method will set the base level (or Zero Level) and the gain (or Slope). As the sensor gets older or the ambient condition changes drastically, the Zero Level may drift upward or downward. The Gain (Slope) will not normally change.

Adjustments of the Zero Level is necessary to ensure that the AST-IRT is reading accurately. This should be done every 6 months. This function can be performed by conducting a Push button Calibration.

PUSH BUTTON -- Located just to the left of the red DIP Switch.

- 1) Make sure the unit is properly wired up and all dip switches are in the off position.
- 2) Allow at least two hours warm up time. The ambient temperature should be stable and within the desired operating range.
- 3) Make sure no refrigerant gas is present during of calibration.
- 4) Depress and hold down the push button (located to the left of DIP SW1) for at least 8 seconds until the calibration LED red light above the push button lights. Release the push button.
- 5) The LED red light will go off. If not, make sure switch 6 is off. Consult factory if calibration LED light stays on or keeps flashing after calibration or during normal operation.

NOTE: If the sensor is reading greater than 80, the sensor will not calibrate. Check for gas leak around the sensor.

AST-IRT Refrigerant Transmitters

MEASURED GAS CALIBRATION

Equipment Required.

1 Refrigerant Sensor Calibration and Test Kit which includes:

- a. Flow Regulating Valve - 1 Liter per minute
- b. Calibration Gas Canister - 79.1% Nitrogen / 20.9% Oxygen (Zero Gas)
- c. Calibration Gas Canister - Nitrogen Balance / Measured quantity of Refrigerant Gas (Span Gas)
- d. Vinyl Tubing for IR Sensor.

The measured gas calibration procedure may be used as a double check of sensor accuracy and only needs to be done if there are questions of whether or not the sensor is working. It is not necessary to use measured gas to calibrate the infrared sensor. This procedure involves changing the air currents drastically inside the sensing chamber, so please use the procedure listed below only as a test. Since the gas is forced into the sensor the reading will not be as accurate as a normal reading. At the factory we allow for normal airflow that would occur in a real leak when we calibrate the sensor and set the zero level. So there will be an artificial reading between the zero gas and measured gas because of the unusual air currents involved.

- 1) Place the Plastic tubing that comes with the calibration kit over the inlet valve located to the right of the wiring plug and connect the other end to the calibration gas canister regulator.
- 2) Run the 20.9% O₂ gas into the sensor for about 5 minutes and wait for the reading to settle. Press the push button on the sensor right above the dipswitch for 10 seconds. This will be the artificial zero level.
- 3) Next run the measured refrigerant gas into the sensor for about 5 minutes. The difference between the artificial measured gas reading and the artificial zero level reading should be close to the measured gas concentration however the way the gas is pumped in will create errors in the accuracy of the reading.
- 4) Once the measured gas testing is complete and no gas is present and the sensor is mounted in normal conditions, do the push button calibration once again to remove any artificial readings that were introduced during measured gas calibration.

INFRARED SENSOR - QUICK START INSTRUCTIONS

1. Mount the sensor in a fixed location and in the proper orientation. (See "Mounting Instructions")
2. Wire the sensor to the Controller. Use only approved wire and double check for proper and secure connections. (See "Wiring Diagrams")

3. Turn on Power to the Sensor and allow warm up time. Check power in and polarity. Warm up time is important to allow time for the Sensor to acclimate to the environment.

A 3 hour warm up is recommended.

4. Calibration and Zeroing of Sensor

The Infrared Sensor is factory calibrated, however the temperature and air quality and other variances make it necessary to calibrate and zero out the sensor at the time of set up in the field and every 6 months.

5. Test the Sensor (Optional)

The sensor may be tested by activating Dip switch 5 or by using a measured gas calibration test kit.

MAINTENANCE SCHEDULE

To aid in performing the maintenance schedule, remember to write down the sensor start up date on the front of the sensor. If it is not written down and a problem due to calibration occurs, this could void the warranty. It is recommended that infrared sensors are zero calibrated every 6 months to insure accuracy. Most of the time push button calibration and control calibration is all that is needed to re zero the sensor and keep it from false alarming. See step 4 of quick start above for more. Measured gas calibration should only be necessary for testing accuracy and if the sensor fails to pick up a leak and is suspected of being damaged or faulty.

AST-IRT Refrigerant Transmitters

TROUBLESHOOTING

LED L1 will indicate if the sensor microprocessor is operating and if the sensor is in test mode using dip switch 5 or pushbutton 1. When the microprocessor goes through start-up, it will turn on L1 and keep it on unless the microprocessor detects a failure of any of the sensor components.

LED L2 is used for calibration of the sensor and is normally off. When the Push Button Calibration is done, L2 will turn on in about 8 seconds then turn off when Push button is released.

LED Status	Condition	Solution
L1 Off	Sensor is not powered up.	Check power connector. Ensure that the sensor is being powered by 12 - 24 VDC. Ensure that wire connections are secure and are correct polarity.
		Microprocessor detects an error in the sensor hardware or Microprocessor Failure. Call CET technical support
L1 On Steady	Sensor is operating properly.	
L1 on Flashing	Switch 5 is on and there is a 200 ppm reading on the sensor	Switch Dip Switch SW5 to other position.
	Microprocessor detects error in the sensor signal.	If switching SW5 does not work, call CET technical support.
L2 Off	Sensor is operating properly.	
L2 On Flashing	Microprocessor Failure	Call CET technical support
L2 On Steady	Sensor is on factory calibration setting	Turn Dip Switch 6 off and wait at least 1 minute for L2 to turn off and do Push Button calibration again.
Sensor Reading	Sensor reading shows the presence of gas.	Was the calibration procedure followed? First attempt Push button procedure. Check area for a leak. Check for wiring problems or the presence of gas.
		Make sure Dip Switches are set to off position.
		How old is the sensor?
	Sensor output has a full scale reading	Check for wiring problems. Turn Dip Switch 5 to on. If the control reads about 200 there could be a sensor problem, contact technical support. If it still reads full scale double check for proper wiring. How old is the sensor?



AST-IRT Refrigerant Transmitters

CONTACT

Critical Environment Technologies
145 - 7391 Vantage Way
Delta, BC V4G 1M3

Toll free: 877-940-8741
Phone: 604-940-8741
Fax: 604-940-8745

www.critical-environment.com